

Reflection of water waves at a straight obstacle

Objects of the experiment

- Investigating the reflection of straight water waves at a straight obstacle.
- Comparing the directions of the incident and reflected wave fronts and confirming the law of reflection (angle of incidence = angle of reflection).
- Investigating the reflection of circular water waves at a straight obstacle.

Principles

Water waves are reflected at obstacles. According to Huygens' principle, we can view the reflected waves as the envelope of the wavelets formed at the obstacle. The reflection at a straight obstacle corresponds to the optical phenomenon of reflection of light at a plane mirror.

To enable observation of reflection, straight waves are generated in the filled wave trough. A reflecting barrier is placed in the trough; the wave fronts and the barrier are not parallel to each

other. The wave "rays" obey the law of reflection: angle of incidence = angle of reflection

When the reflecting barrier and the straight wave front are aligned parallel to each other, standing waves are generated. We will take a closer look at these in the experiment "Standing waves in front of a reflecting barrier", as part of the topic group "Interference of water waves".

When circular waves are reflected, the reflected waves are also concentric. Each of the radial wave rays is reflected at the barrier in accordance with the law of reflection. The center of the reflected circular waves is in the "mirror point" of the exciter.

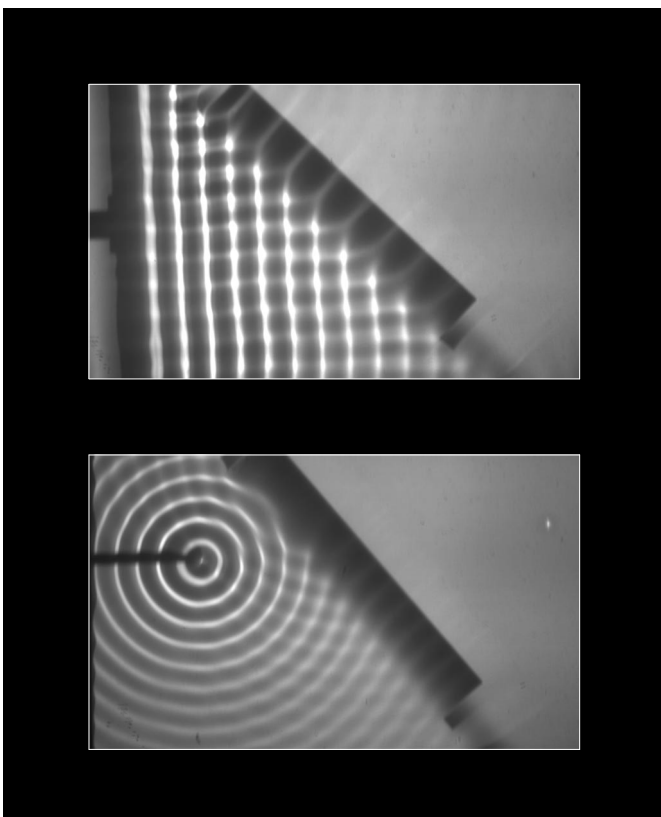

Fig. 1 Reflection of water waves at a straight obstacle (photographs)
Top: straight waves
Bottom: circular waves

Apparatus

1 Wave trough with motor stroboscope 401 501

additionally required:

Dish soap,
transparencies, transparency pens, adhesive tape,
ruler, protractor

Setup

Set up the experiment as shown in Fig. 2.

- Set up the wave trough so that it is not subject to shocks and vibrations; observe all information given in the Instruction Sheet. Use a spirit level and make sure that the glass plate is aligned precisely horizontally.
- Connect the exciter for straight waves as shown in Fig. 3 and place the reflecting barrier at an angle of 45° to the exciter in the middle of the wave trough.
- Attach a transparency to the observation screen **(g)** using adhesive tape.

Carrying out the experiment**a) Reflection of straight water waves:**

- If necessary, rotate the stroboscope disk out of the beam path using knurled screw **(f)** so that the glass pane in the bottom of the wave trough is completely illuminated.
- Using knob **(e)**, set a frequency of approx. 20 Hz, and carefully increase the excitation amplitude using knob **(d)** until reflected wave fronts are clearly visible (see Instruction Sheet for wave trough).
- Vary the immersion depth of the exciter as necessary with adjusting screw **(h1)**.
- Measure and compare the directions of propagation and the wavelengths of the incident and reflected wave fronts.
- Carry out the experiment with different excitation frequencies between 10 - 30 Hz.
- To quantitatively compare the directions of propagation and the wavelengths, switch on the stroboscope with switch **(a)**; after a short warm-up time, you may need to carry out a fine adjustment of the excitation and stroboscope frequencies using knob **(b)** until a stationary wave image appears.
- Sketch the reflecting barrier, the directions of propagation and the spacing of the wave fronts on the transparency.
- Draw in the axis of incidence and measure the angle of incidence and angle of reflection.
- Measure and compare the wavelength in both zones.
- Change the orientation of the incident waves by turning the reflecting barrier, and measure and compare the angle of incidence and refractive angle for each position.
- Repeat the experiment for various excitation frequencies of 10 - 60 Hz; if necessary, carry out fine adjustment of the system.
- Repeat the experiment with a wave packet. If necessary, rotate the stroboscope disk out of the beam path, turn amplitude knob **(d)** all the way to the left and press pushbutton **(c)** for single-wave excitation.

b) Reflection of circular waves:

- Connect the point-type exciter as shown in Fig. 4 so that the tip of the exciter is about 4 cm in front of the reflecting barrier.
- Adjust the amplitude so that reflected wave fronts are clearly visible. Vary the immersion depth as necessary with adjusting screw **(h2)**.
- Measure and compare the directions of propagation and the wavelengths of the incident and reflected wave fronts.
- Carry out the experiment with different excitation frequencies between 10 - 30 Hz.
- Using the stroboscope, generate stationary wave images. Set excitation frequencies from 10-60 Hz.
- Repeat the experiment with a wave packet.

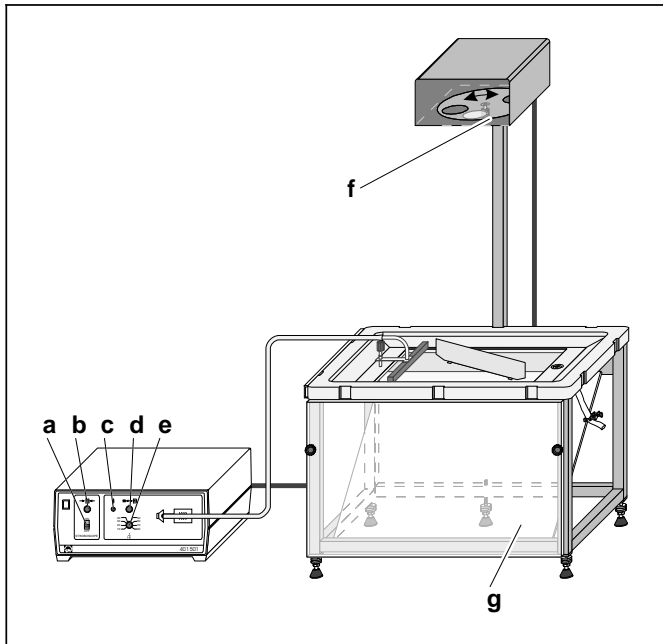

Fig. 2 Experiment setup for reflection of water waves at a straight obstacle

- a Stroboscope switch
- b Knob (for fine adjustment of stroboscope frequency)
- c Pushbutton (single-wave excitation)
- d Knob (for adjusting amplitude of wave excitation)
- e Knob (for adjusting frequency of wave excitation)
- f Knurled screw (for manually turning stroboscope disk)
- g Observation screen

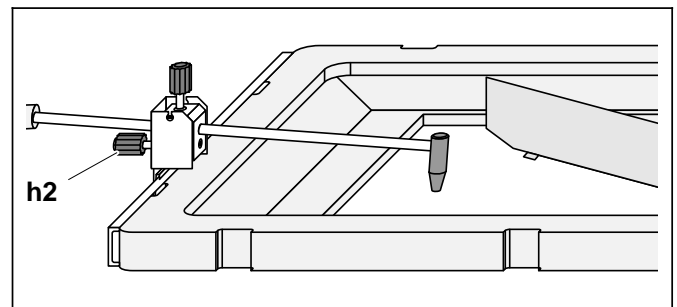
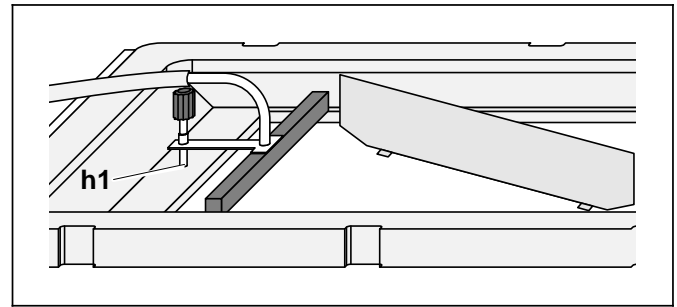

Fig. 3 Connecting the exciter for straight waves and setting up the reflecting barrier

- h1 Adjusting screw (for setting immersion depth)

Fig. 4 Connecting the point-type exciter for circular waves and setting up the reflecting barrier

- h2 Adjusting screw (for setting immersion depth)

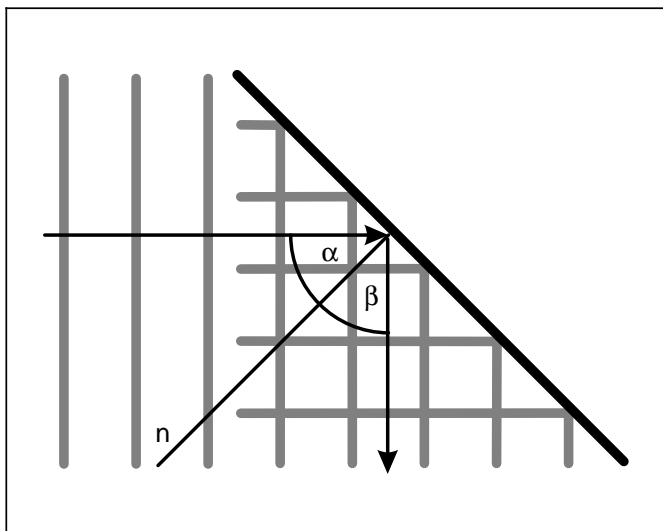

Fig. 5 Reflection of straight waves at a straight obstacle (diagram on transparency)

- n: axis of incidence
- α : angle of incidence, here: 45°
- β : angle of reflection, here: 45°

Measuring example

a) Reflection of straight water waves:

The top photograph in Fig. 1 shows the reflection of straight water waves at a straight obstacle.

b) Reflection of circular waves:

The bottom photograph in Fig. 1 shows the reflection of circular water waves at a straight obstacle.

Results

a) Reflection of straight water waves:

Straight water waves are reflected at the reflecting barrier. The reflected waves are themselves straight. The wavelength is unchanged.

The angle between the direction of the incoming waves and the axis of incidence is equal to the angle between the reflected waves and the axis of incidence (see Fig. 5): angle of incidence α = angle of reflection β .

b) Reflection of circular waves:

Circular water waves are reflected at the reflecting barrier. The reflected waves are themselves circular. The center of the reflected circular waves is the "mirror point" of the exciter.