

## Determining the phase velocity of circularly polarized thread waves in the experiment setup after *Melde*

### Objects of the experiment

- Generating standing, circularly polarized thread waves for various tension forces  $F$ , thread lengths  $s$  and thread densities  $m^*$ .
- Determining the phase velocity  $c$  of thread waves as a function of the tension force  $F$ , the thread length  $s$  and thread density  $m^*$ .

### Principles

The propagation speed of a wave in a medium is calculated using *d'Alembert's* wave equation. For an elastically tensioned thread, we compare e.g. the restoring force acting on a section of the thread deflected from its resting position with the inertial

force of this piece of thread. The result for the propagation speed is

$$c = \sqrt{\frac{F}{A \cdot \rho}}$$

( $F$  = tension force,  $A$  = thread cross-section,  $\rho$  = density of the thread material)

respectively

$$c = \sqrt{\frac{F}{m^*}} \quad \text{with } m^* = \frac{m}{s} \quad (I)$$

( $m$  = mass of thread,  $s$  = thread length).

In the experiment arrangement after *Melde*, standing, circularly polarized waves are generated in a thread with known length  $s$ . The tension force  $F$  is varied until waves with the wavelength

$$\lambda_n = \frac{2s}{n} \quad (II)$$

$n$  = number of oscillation nodes)

are obtained. The additional determination of the frequency  $f$  using a stroboscope enables calculation of the propagation speed according to the formula

$$c = \lambda \cdot f \quad (III)$$

If the mass and the length of the thread are additionally measured, it becomes possible to verify equation (I).

The stroboscope is recommended not only for measuring the frequency: when the standing thread wave is illuminated with light flashes at a frequency approximating the excitation frequency, the oscillations of the thread seem to slow down and the circular polarization of the waves becomes visible in a highly impressive manner.

Fig. 1 Arrangement for the experiment after *Melde*

- (a) Cam
- (b) Mounting point for thread length  $s = 0.35$  m
- (c) Mounting point for thread length  $s = 0.48$  m
- (d) Deflection pulley
- (e) Holding arm
- (f) Dynamometer

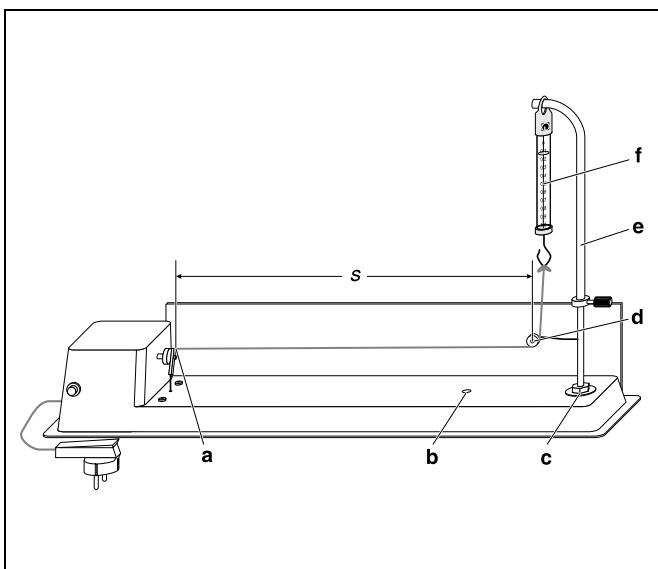

### Setting up and carrying out the experiment

Set up the experiment as shown in Fig. 1.

**Apparatus**

1 Vibrating thread apparatus . . . . .	401 03
1 Stroboscope, 220 V, 50 Hz . . . . .	451 28
1 School and lab balance . . . . .	315 05
1 Tape measure, 2 m . . . . .	311 77

**Preparation:**

- Cut up the thread supplied with the apparatus into three pieces of different lengths:
- Cut off a piece 0.65 m long as thread 1 for experiment part a.
- Cut off a piece 0.50 m long as thread 2 for experiment part b.
- Cut off a piece approx. 2.60 m long as thread 3, fold it over itself four times; entwine the thread pieces together and tie their ends.

*Important: start each measurement with the completely detensioned thread and vary the tension by slowly and carefully moving holding arm (e).*

**a) Wavelength  $\lambda$  and phase velocity  $c$  as a function of the tension force  $F$**

- Set up the holding arm (e) of the vibrating thread apparatus at position (c).
- Tie one end of thread 1 to cam (a).
- Tie a loop in the other end and hang this on the dynamometer (f).
- Measure the distance between cam (a) and the center of the deflection pulley (d) (= thread length  $s$ ) and write this value in the experiment log.
- Switch on the motor of the apparatus.
- With the adjusting screw loosened, vary the force  $F$  by changing the height of the holding arm (e) until a standing wave of maximum amplitude with the wavelength  $\lambda = 2s$  is formed (one oscillation antinode).
- Read off the corresponding force  $F_1$  and write this value in the experiment log.
- By slowly and carefully varying the height of holding arm (e), determine the forces  $F_n$  at which standing waves with  $n = 2, 3, 4$  and  $5$  antinodes are formed.
- For each standing wave, use the stroboscope to determine the excitation frequency  $f$ . To do this, start from the maximum stroboscope frequency and slowly reduce the frequency until a simple standing sinusoidal wave first becomes visible.
- Write down the number  $n$  of nodes, the corresponding force  $F_n$  and the frequency  $f$  in the experiment log.
- Switch off the motor.
- Untie the thread and measure the mass  $m_0$  and the length  $s_0$  of the thread so that the density  $m^* = \frac{m_0}{s_0}$  of the thread can be calculated.

**b) The influence of thread length  $s$  and thread mass  $m$ :**

- Set up holding arm (e) of the vibrating thread apparatus at position (b).
- Attach thread 2.
- Measure the distance between cam (a) and the center of the deflection pulley (d) (= thread length  $s$ ) and write this value in the experiment log.
- Switch on the motor of the apparatus.
- Determine the forces  $F_n$  and the frequencies  $f$  at which standing waves with  $n = 1, 2, 3$  and  $4$  anti nodes are formed.
- Switch off the motor.
- Measure the mass  $m_0$  and the length  $s_0$  of the thread.

**c) Wavelength  $\lambda$  and phase velocity  $c$  as a function of the density  $m^*$ :**

- Set up the holding arm (e) of the vibrating thread apparatus at position (c).
- Attach thread 3.
- Switch on the motor.
- Determine the forces  $F_n$  and the frequencies  $f$  at which standing waves with  $n = 1, 2, 3, 4, 5$  and  $6$  antinodes are formed.
- Switch off the motor.
- Measure the mass  $m_0$  and the length  $s_0$  of the thread.

**Measuring example**

Tables 1 a, b, and c show the measurement results for experiment parts a), b) and c).

Table 1: Frequency  $f$  and tension force  $F_n$  for a standing wave with  $n$  oscillation nodes

a) Thread 1 with  $s = 0.48$  m,  $m^* = 0.43 \frac{\text{g}}{\text{m}}$

$n$	$\frac{f}{\text{Hz}}$	$\frac{F}{\text{N}}$
1	47	0.875
2	48	0.225
3	48	0.1
4	48	0.05
5	48	0.025

b) Thread 2 with  $s = 0.35$  m,  $m^* = 0.43 \frac{\text{g}}{\text{m}}$

$n$	$\frac{f}{\text{Hz}}$	$\frac{F}{\text{N}}$
1	47	0.5
2	47	0.125
3	48	0.05
4	48	0.025

c) Thread 3 with  $s = 0.48$  m,  $m^* = 1.74 \frac{\text{g}}{\text{m}}$

$n$	$\frac{f}{\text{Hz}}$	$\frac{F}{\text{N}}$
2	46	0.92
3	47	0.425
4	47	0.25
5	47	0.15
6	47	0.1

**Evaluation and results**

Table 2: Evaluation of the measurement results from Table 1

a) Thread 1 with  $s = 0.48 \text{ m}$ ,  $m^* = 0.43 \frac{\text{g}}{\text{m}}$

$n$	$\frac{\lambda}{\text{m}}$	$\frac{c}{\text{m s}^{-1}}$	$\frac{\sqrt{\frac{F}{m^*}}}{\text{m s}^{-1}}$
1	0.96	45.1	45.1
2	0.48	23.0	22.8
3	0.32	15.4	15.2
4	0.24	11.5	10.8
5	0.19	9.1	7.6

b) Thread 2 with  $s = 0.35 \text{ m}$ ,  $m^* = 0.43 \frac{\text{g}}{\text{m}}$

$n$	$\frac{\lambda}{\text{m}}$	$\frac{c}{\text{m s}^{-1}}$	$\frac{\sqrt{\frac{F}{m^*}}}{\text{m s}^{-1}}$
1	0.70	32.9	34.1
2	0.35	16.5	17.0
3	0.23	11.0	10.8
4	0.18	8.6	7.6

c) Thread 3 with  $s = 0.48 \text{ m}$ ,  $m^* = 1.74 \frac{\text{g}}{\text{m}}$

$n$	$\frac{\lambda}{\text{m}}$	$\frac{c}{\text{m s}^{-1}}$	$\frac{\sqrt{\frac{F}{m^*}}}{\text{m s}^{-1}}$
2	0.48	22.1	23.1
3	0.32	15.0	15.6
4	0.24	11.3	12.0
5	0.19	8.9	9.3
6	0.16	7.5	7.6

The wavelengths  $\lambda_n$  calculated from the number of oscillation nodes  $n$  according to equation (II) are given in Tables 2 a, b and c. The tables also contain the phase velocities calculated using equation (III) as well as the expression  $\sqrt{\frac{F}{m^*}}$ . Fig. 2 shows

the graph of  $\sqrt{\frac{F}{m^*}}$ . As the measured values lie with good approximation on a straight line through the origin with the slope 1, this confirms equation (I).

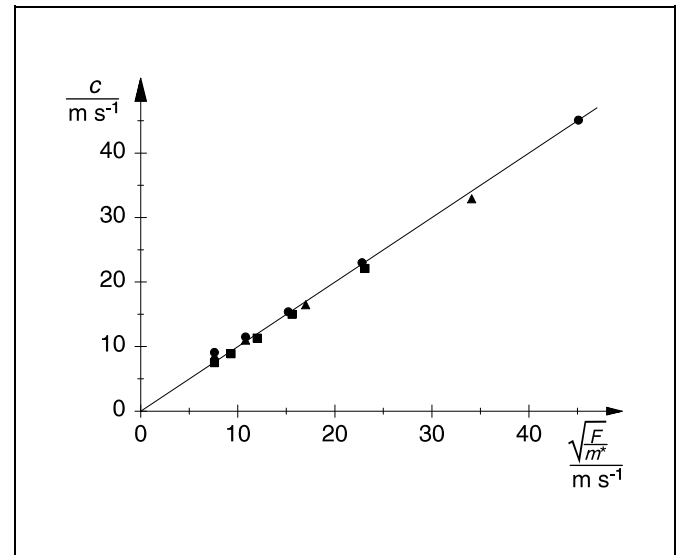

Fig. 2 Graph of  $c = f(\sqrt{\frac{F}{m^*}})$ .

Circles: data from Table 2a

Triangles: data from Table 2b

Squares: data from Table 2c