

Investigating circularly polarized thread waves in the experiment setup after *Melde*

Objects of the experiment

- Generating standing, circularly polarized thread waves for various tension forces F , thread lengths s and thread densities m^* .
- Determining the wavelength λ of thread waves as a function of the tension force F , the thread length s and thread density m^* .

Principles

The propagation speed of a wave in a medium is calculated using *d'Alembert's* wave equation. For an elastically tensioned thread, we compare e.g. the restoring force acting on a section of the thread deflected from its resting position with the inertial force of this piece of thread. The result for the propagation speed is

$$c = \sqrt{\frac{F}{A \cdot \rho}} \quad (I)$$

(F = tension force, A = thread cross-section, ρ = density of the thread material)

Thus, at a fixed excitation frequency f , the following applies for the wavelength λ :

$$\lambda \sim \sqrt{\frac{F}{m^*}} \quad \text{mit } m^* = \frac{m}{s} \quad (II)$$

(m = mass of thread, s = thread length).

In the experiment arrangement after *Melde*, standing, circularly polarized waves are generated in a thread with known length s . The tension force F is varied until waves with the wavelength

$$\lambda_n = \frac{2s}{n} \quad (III)$$

(n = number of oscillation nodes)

are obtained. Using the measurement data obtained in this manner, it becomes possible to verify equation (II).

Fig. 1 Arrangement for the experiment after *Melde*
(a) Cam
(b) Mounting point for thread length $s = 0.35$ m
(c) Mounting point for thread length $s = 0.48$ m
(d) Deflection pulley
(e) Holding arm
(f) Dynamometer

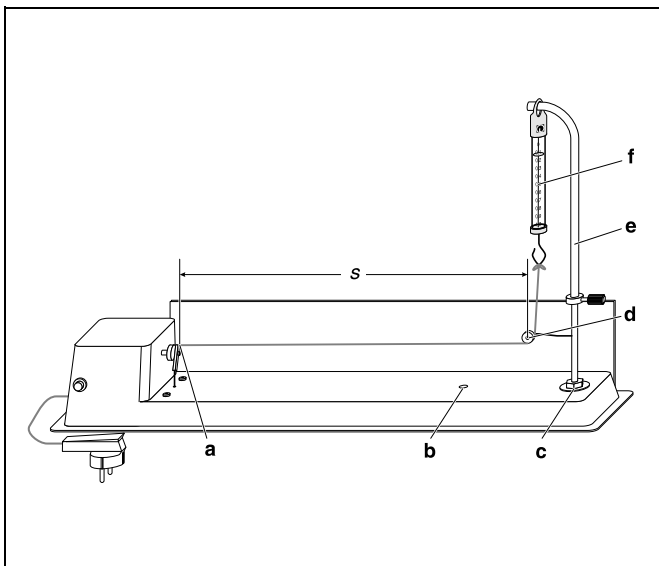

Setting up and carrying out the experiment

Set up the experiment as shown in Fig. 1.

Apparatus

- 1 Vibrating thread apparatus 401 03
- 1 Tape measure, 2 m 311 77

Preparation:

- Cut up the thread supplied with the apparatus into three pieces of different lengths:
Cut off a piece 0.65 m long as thread 1 for part a.
Cut off a piece 0.50 m long as thread 2 for part b.
Cut off a piece approx. 2.60 m long as thread 3, fold it over itself four times; entwine the thread pieces together and tie their ends.

Important: start each measurement with the completely detensioned thread and vary the tension by slowly and carefully changing holding arm (e).

a) Wavelength λ as a function of the tension force F

- Set up the holding arm (e) of the vibrating thread apparatus at position (c).
- Tie one end of thread 1 to cam (a).
- Tie a loop in the other end, hang this on the dynamometer (f).
- Measure the distance between cam (a) and the center of the deflection pulley (d) (= thread length s) and write this value in the experiment log.
- Switch on the motor of the apparatus.
- With the adjusting screw loosened, vary the force F by changing the height of the holding arm (e) until a standing wave of maximum amplitude with the wavelength $\lambda = 2s$ is formed (one oscillation antinode).
- Read off the corresponding force F_1 and write this value in the experiment log.
- By slowly and carefully varying the height of holding arm (e), determine the forces F_n at which standing waves with $n = 2, 3, 4$ and 5 antinodes are formed.
- Write down the number n of nodes, the corresponding force F_n and the frequency f in the experiment log.
- Switch off the motor.

b) The influence of thread length s and thread mass m :

- Set up holding arm (e) of the vibrating thread apparatus at position (b).
- Attach thread 2.
- Measure the distance between cam (a) and the center of the deflection pulley (d) (= thread length s) and write this value in the experiment log.
- Switch on the motor of the apparatus.
- Determine the forces F_n and the frequencies f at which standing waves with $n = 1, 2, 3$ and 4 antinodes are formed.
- Switch off the motor.

c) Wavelength λ and phase velocity c as a function of the density m^* :

- Set up the holding arm (e) of the vibrating thread apparatus at position (c).
- Attach thread 3.
- Switch on the motor.
- Determine the forces F_n and the frequencies f at which standing waves with $n = 2, 3, 4, 5$ and 6 antinodes are formed.
- Switch off the motor.

Measuring example

Tables 1 a, b, and c show the measurement results for experiment parts a), b) and c).

Table 1: Tension force F_n for a standing wave with n oscillation nodes

- a) Thread 1 with single density value, $s = 0.48$ m
- b) Thread 2 with single density value, $s = 0.35$ m
- c) Thread 3 with single density value, $s = 0.48$ m

	thread 1	thread 2	thread 3
n	$\frac{F}{N}$	$\frac{F}{N}$	$\frac{F}{N}$
1	0.875	0.5	
2	0.225	0.125	0.925
3	0.1	0.05	0.425
4	0.05	0.025	0.25
5	0.025		0.15
6			0.1

Evaluation and results

The values $\sqrt{F_n}$ and the wavelengths λ_n calculated from the number of oscillation nodes n using equation (II) are given in Table 2 a, b and c. Fig. 2 shows the corresponding graph $\lambda = f(\sqrt{F})$.

Table 2: Evaluation of the measurement results from Table 1

n	thread 1		thread 2		thread 3	
	$\sqrt{\frac{F}{N}}$	$\frac{\lambda}{m}$	$\sqrt{\frac{F}{N}}$	$\frac{\lambda}{m}$	$\sqrt{\frac{F}{N}}$	$\frac{\lambda}{m}$
1	0.94	0.96	0.71	0.70		
2	0.47	0.48	0.35	0.35	0.96	0.48
3	0.32	0.32	0.22	0.23	0.65	0.32
4	0.22	0.24	0.16	0.18	0.50	0.24
5					0.39	0.19
6					0.32	0.16

The wavelength λ_n of the threads increases with the tension force F , and the number of oscillation nodes n decreases. The graph $\lambda = f(\sqrt{F})$ shows the same slope for threads of the same density $\frac{m}{s}$ regardless of the length s of the thread. For threads with four times the density, the slope is half as great.

Fig. 2: Graph of $\lambda = f(\sqrt{F})$.
Circles: data from Table 2a
Triangles: data from Table 2b
Squares: data from Table 2c

