

Wheel and axle as a lever with unequal sides

Objects of the experiment

- Measuring the force F_1 as a function of the load L_2 and comparison of the angular momentums.
- Measuring the force F_1 as a function of the load arm r_2 and comparison of the angular momentums.
- Experimental investigation of the definition of the power arm and the line of action.

Principles

A rigid body which can rotate around a point O is turned by a force F acting on a point P, as the angular momentum

$$M = r \times F \quad (I)$$

r : local vector from O to P

acts upon it. The angular momentum is a vectorial quantity which is perpendicular to the plane running between the vectors r and F . Its absolute value

$$M = F \cdot r \cdot \sin \alpha \quad (II)$$

α : angle between vectors r and F

can be represented as the product of the force F and the power arm a . Here, the power arm

$$a = r \cdot \sin \alpha \quad (III)$$

is the straight line running from the axis O through the point of application P in the direction of force F (see Fig. 1). The power arm remains unchanged when the point of application of force F is shifted along the line of action; thus the angular momentum does not change. When the force F is perpendicular to position vector r , the position vector and the power arm are identical, and the angular momentum is defined by the relationship

$$M = F \cdot r \quad (IV)$$

If forces with an opposing rotational direction act on the body, we can distinguish between "clockwise" and "counterclockwise" angular momentums. Equilibrium is achieved when the sum M_1 of the counterclockwise moments is equal to the sum M_2 of the clockwise moments:

$$M_1 = M_2 \quad (V)$$

When expressed in the form "force x power arm = load x load arm", this relationship is referred to as the law of levers.

The wheel and axle are ideal for investigating the equilibrium of angular momentums. A thread can be placed in the grooves arranged concentrically to the axis of rotation so that the force F is applied tangentially at any point along the circumference and the angular momentum is determined according to (IV). As the wheel is provided with grooves with three different radii (2.5 cm, 7.5 cm and 10.0 cm), the wheel and axle can be used as a lever with unequal sides and the force F_1 which keeps the wheel and axle in equilibrium is determined as a function of the load F_2 , the load arm r_2 and the power arm r_1 . The load is applied using multiple 50 g weights suspended one below the other. For the load

$$F_2 = m \cdot g$$

g : gravitational acceleration

of a weight, the value 0.5 N can be assumed with sufficient accuracy.

The wheel is also provided with regularly arranged holes to accommodate brass rods, from which loads can also be suspended. When the system is aligned so that a row of holes is precisely along the line of action of an applied force, it becomes possible to demonstrate the shift of the point of application along the line of action.

Fig. 1 Definition of the angular momentum $M = r \times F$
 a : power arm
XY: line of action

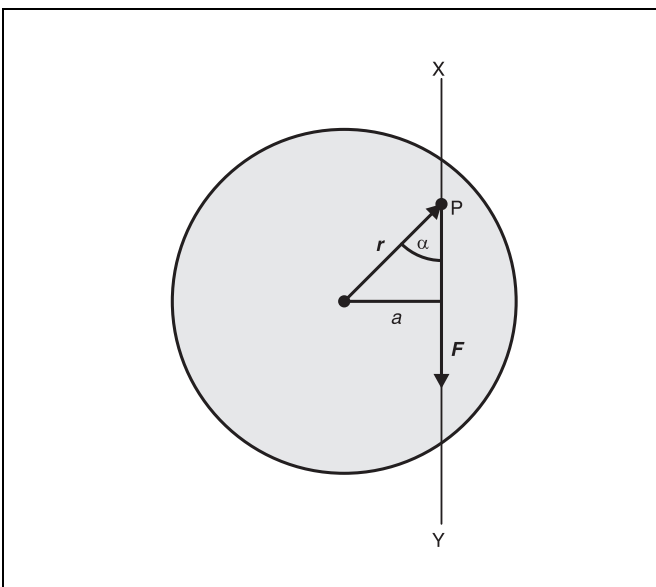

Apparatus

1 Metal wheel and axle	342 75
1 Set of 12 weights, 50 g each	342 61
1 Dynamometer, 2.0 N	314 45
1 Dynamometer, 5.0 N	314 46
1 Stand base, V-shape, 20 cm	300 02
1 Leybold multiclamp	301 01
1 Stand rod, 47 cm	300 42

Carrying out the experiment

a) Wheel and axle as a lever with unequal sides: measuring the force F_1 as a function of the load F_2

- Attach the short thread to the pin of the inside groove (radius: 2.5 cm) and suspend two weights from this.
- Attach the long thread to the pin of the outside groove (radius: 10 cm), lay it over at least one quarter of the circumference and suspend the dynamometer from the thread.
- Measure and write down the force F_1 which maintains the equilibrium of the setup.
- Repeat the measurement with 4, 6 and 8 weights.

b) Wheel and axle as a lever with unequal sides: measuring the force F_1 as a function of the load arm r_2 and the power arm r_1

- Hang the short thread with four weights on the pin on the middle groove (radius 7.5 cm) and the outer groove and measure the force F_1 each time.
- Wind the long thread around the middle and the inside groove one after the other and measure the force F_1 each time.

c) Definition of the power arm: shifting the point of application along the line of action

- Set up the wheel and axle as shown in Fig. 3 so that the four rows of holes are vertical and insert the brass pins into holes (A₁₋₃), (B₁₋₅) and (C).
- Hang a thread with four weights each at positions (B₁) and (C) and observe the equilibrium.
- Move the left thread with four weights to positions (B₂₋₅) one after another and observe the equilibrium.
- Move the left thread with two weights to positions (A₁₋₃) one after another and observe the equilibrium.

Setup

Set up the experiment as shown in Fig. 2.

- Mount the stand rod in the stand base.
- Attach the wheel and axle to the stand rod using the Leybold multiclamp.
- Prepare one thread 15–20 cm long and one thread 50–60 cm long and tie a loop in both ends of each thread.

Fig. 2 Experiment setup for wheel and axle as a lever with unequal sides

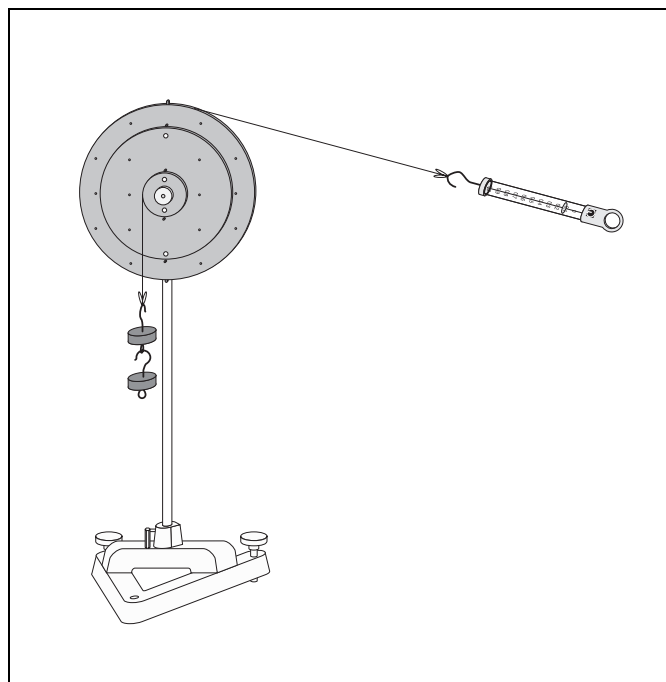
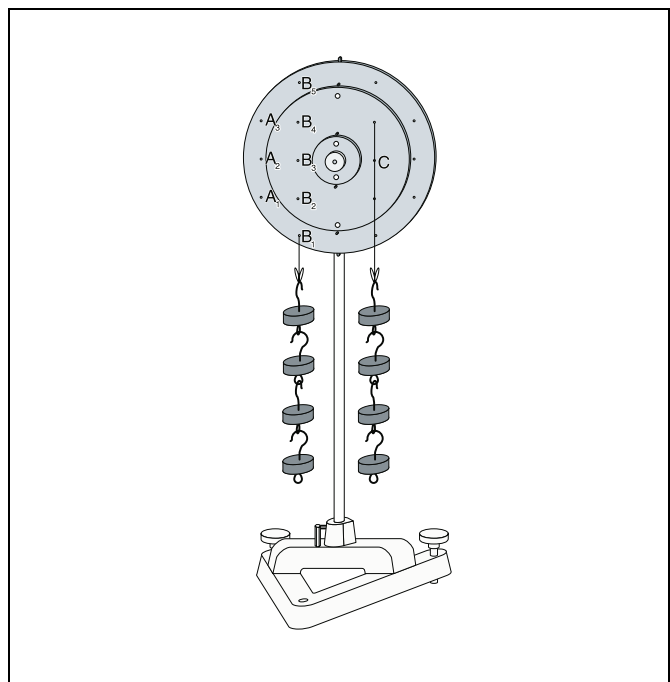

Fig. 3 Experiment setup for shifting the point of application along the line of action



Measuring example and evaluation

a) Wheel and axle as a lever with unequal sides: measuring the force F_1 as a function of the load F_2

Table 1: Force F_1 measured as a function of the load F_2 and angular momentums M_1 und M_2 according to (IV)
($r_1 = 2.5$ cm, $r_2 = 10$ cm)

$\frac{m_2}{g}$	$\frac{F_2}{N}$	$\frac{F_1}{N}$	$\frac{M_1}{Nm}$	$\frac{M_2}{Nm}$
100	1.0	0.25	0.025	0.025
200	2.0	0.50	0.050	0.050
300	3.0	0.75	0.075	0.075
400	4.0	1.00	0.100	0.100

b) Lever with unequal sides: measuring the force F_1 as a function of the load arm F_2

Table 2: Force measured as a function of the load arm r_2 and angular momentums M_1 und M_2 according to (IV)
($m_2 = 100$ g, $F_2 = 1$ N)

$\frac{r_1}{cm}$	$\frac{r_2}{cm}$	$\frac{F_1}{N}$	$\frac{M_1}{Nm}$	$\frac{M_2}{Nm}$
10.0	2.5	0.25	0.025	0.025
10.0	7.5	0.75	0.075	0.075
10.0	10.0	1.0	0.10	0.10
7.5	10.0	1.25	0.094	0.10
2.5	10.0	4.0	0.10	0.10

c) Definition of the power arm: shifting the point of application along the line of action

Clockwise angular momentum:

Point of application (C):

Force $F = 2.0$ N, power arm $r = 4$ cm: $M = 0.08$ Nm

Counterclockwise angular momentum

Points of application (B₁) – (B₅):

Force $F = 2.0$ N, power arm $r = 4$ cm: $M = 0.08$ Nm

Points of application (A₁) – (A₃):

Force $F = 1.0$ N, power arm $r = 8$ cm: $M = 0.08$ Nm

Results

The wheel and axle is in equilibrium when the “clockwise” and “counterclockwise” angular momentums are equal. This equilibrium condition is identical to the law of levers “force x power arm = load x load arm”.

The angular momentum does not change when the point of application of the force is shifted along the line of action.