

Determining the density of liquids using the Mohr density balance

Objects of the experiments

- Determining the density of pure water and checking the measuring accuracy of the density balance.
- Determining the density of ethanol-water solutions as a function of the volume concentration of the ethanol.

Principles

The density of a liquid can be determined with a high degree of accuracy by means of a Mohr density balance:

A plummet immersed into the liquid is acted upon by an upward buoyancy force and thus apparently loses weight. The magnitude of the buoyancy force is equal to the weight of the liquid displaced by the plummet and, therefore, proportional to the density of the liquid. The apparent loss of weight is balanced at the beam with balancing weights. The density can be immediately read from the positions of the balance weights. At the reference temperature $\vartheta = 20\text{ }^{\circ}\text{C}$, liquid densities between 0.8 g cm^{-3} and 1.1 g cm^{-3} can thus be determined to an accuracy of $\Delta\rho = 0.0003\text{ g cm}^{-3}$. Beyond this range, the display of the balance must be corrected since air buoyancy and a liquid bulge at the plummet wire affect the measurement.

The mixture of two liquids with different densities ρ_1 and ρ_2 is studied in the experiment. Consider the following with regard to the density ρ of the mixture (more precisely: the solution):

The partial volumes V_1 and V_2 correspond to the partial masses $m_1 = \rho_1 \cdot V_1$ and $m_2 = \rho_2 \cdot V_2$ (I).

The total mass of the solution is certainly equal to the sum of the partial masses, and therefore

$$m = \rho_1 \cdot V_1 + \rho_2 \cdot V_2 \quad \text{(II)}$$

In the case of an ideal solution, the partial volumes add to the total volume

$$V = V_1 + V_2 \quad \text{(III)}$$

From this

$$\rho = \rho_1 \cdot \frac{V_1}{V_1 + V_2} + \rho_2 \cdot \left(1 - \frac{V_1}{V_1 + V_2}\right) \quad \text{(IV)}$$

follows, that is, the density of the ideal solution has a linear dependence on the volume concentration

$$c = \frac{V_1}{V_1 + V_2} \quad \text{(V)}$$

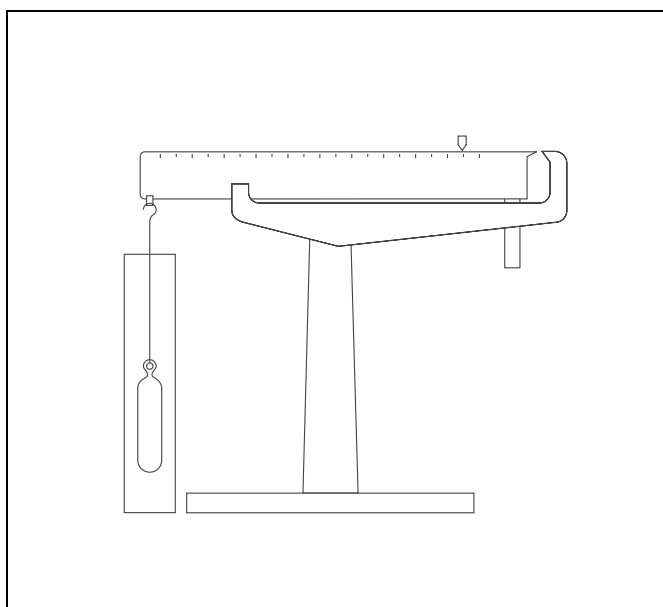

Apparatus

- 1 density balance (Mohr Westphal) 316 07
- 2 graduated cylinders, 100 ml: 1 665 754
- 1 ethanol, denaturated, 1 l 671 972

additionally required:

distilled or demineralized water

Setup

The experimental setup is illustrated in Fig. 1.

- Insert the balance beam with the needle into the stand from above and put it in the centre bearing.
- Clean the plummet, dry it, and hang it on the hanger.
- Position balancing weight 1 at the notch "0.00" and balancing weight 2 at the notch "0.0000". Mount the hang-up weight.
- Calibrate the zero position by turning the level screw, and, if necessary, readjust the balance spindle until both needles have the same height.

Fig. 1 Experimental setup with the Mohr density balance

- a plummet
- b plummeting jar
- c balance spindle
- d balance beam
- e centre bearing
- f balancing weight 1
- g balancing weight 2
- h needle
- i hang-up weight
- k level screw

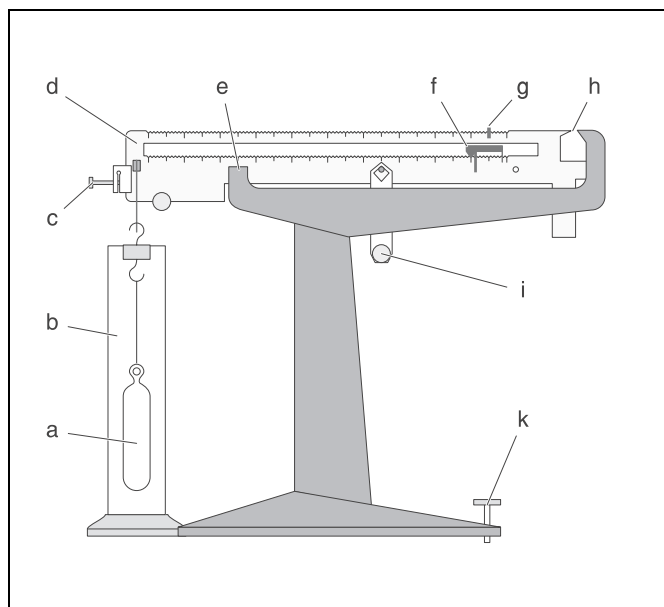

Carrying out the experiment

Note:

Incomplete immersion of the plummet into the liquid, friction of the plummet on the wall of the jar, air bubbles on the plummet or liquid drops on the suspension of the plummet can distort the measuring result.

a) Measurement with pure water:

- Remove the plummet from the balance beam, and fill 90 ml of pure water into the jar.
- Hold the plummet by the suspension, immerse it into the liquid, move it together with the jar under the balance beam, and hang it on the hanger.
- Hang the thermometer in the jar.
- Shift the balancing weights until the two needles have the same height.
- Read the density, that is, the sum of the two scale values, and record it.

b) Measurement with ethanol-water solutions:

- Repeat the measurement with pure ethanol and, subsequently, with ethanol-water solutions.
- Clean the plummet and the jar carefully each time, and fill 90 ml of the liquid into the jar.
- Read the density which, again, is the sum of the two scale values and record it together with the volume concentration *c* of the ethanol.

The following procedure is recommended in order to prepare an ethanol-water solution of a desired volume concentration *c* of the ethanol:

- Fill the volume $V_1 = c \cdot 100$ ml of ethanol into graduated cylinder 1.
- Fill the volume $V_2 = (1 - c) \cdot 100$ ml of water into graduated cylinder 2.
- Carefully mix both liquids in one graduated cylinder and fill about 90 ml of the solution into the jar of the density balance.

Measuring example

a) Measurement with pure water:

$\vartheta = 22 \text{ }^\circ\text{C}$

$\rho = 0.9975 \text{ g cm}^{-3}$

b) Measurement with ethanol-water solutions:

Table 1: Measuring result for the density ρ as a function of the volume concentration of the ethanol

<i>c</i>	$\frac{\rho}{\text{g} \cdot \text{cm}^{-3}}$	<i>c</i>	$\frac{\rho}{\text{g} \cdot \text{cm}^{-3}}$
1.0	0.7885	0.5	0.9242
0.9	0.8243	0.4	0.9429
0.8	0.8517	0.3	0.9595
0.7	0.8793	0.2	0.9724
0.6	0.9019	0.1	0.9835

Evaluation and results

a) Measurement with pure water:

The density of water at $\vartheta = 22\text{ °C}$, as quoted in the literature, is $\rho = 0.9978\text{ g cm}^{-3}$ according to Table 2.

The measuring result $\rho = 0.9975\text{ g cm}^{-3}$ agrees with this value within the accuracy of measurement.

Table 2: Values quoted in the literature for the density ρ of pure water as a function of the temperature ϑ :

ϑ	$\frac{\rho}{\text{g} \cdot \text{cm}^{-3}}$	ϑ	$\frac{\rho}{\text{g} \cdot \text{cm}^{-3}}$
15 °C	0.999099	23 °C	0.997540
16 °C	0.998943	24 °C	0.997299
17 °C	0.998775	25 °C	0.997047
18 °C	0.998596	26 °C	0.996785
19 °C	0.998406	27 °C	0.996515
20 °C	0.998205	28 °C	0.996235
21 °C	0.997994	29 °C	0.995946
22 °C	0.997772	30 °C	0.995649

b) Measurement with ethanol-water solutions:

In Fig. 2, the measuring results are plotted as circles. They are considerably higher than the dashed line, which represents the linear relation expected according to Eq. (IV).

Alcohol and water form a real solution, which shows a volume contraction so that the volume V turns out to be smaller than the value calculated from Eq. (III).

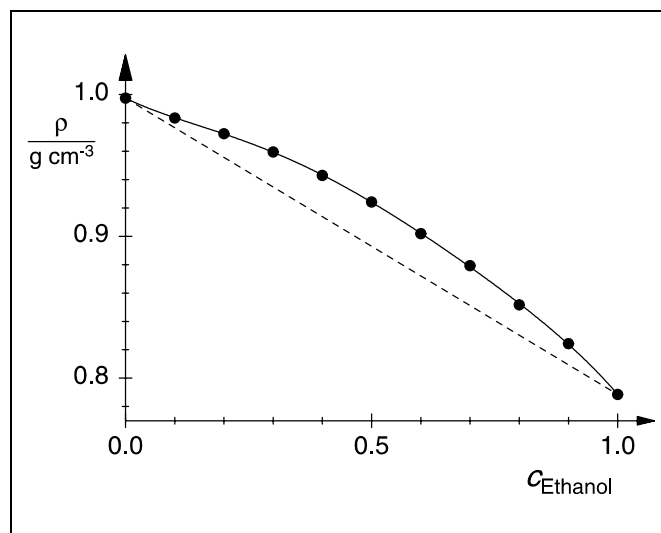

Fig. 2 The density ρ of an ethanol-water solution as a function of the volume concentration of the ethanol

Supplementary information

The total consumption of ethanol can be considerably reduced if the concentrations are suitably halved in one series of measurements by mixing 50 ml of a solution with 50 ml of pure water.

The following dilutions are possible:

- $c = 1 \rightarrow c = 0.5$;
- $c = 0.8 \rightarrow c = 0.4 \rightarrow c = 0.2 \rightarrow c = 0.1$
- $c = 0.6 \rightarrow c = 0.3$

The volume contraction is neglected here in the calculation of the concentration.