

Determining the volume and density of solids

Objects of the experiments

- Measuring the volumes V of different bodies according to the overflow method.
- Comparing the volumes measured with those calculated from the dimensions.
- Determining the density ρ of the bodies.

Principles

The density of a homogeneous substance is usually determined by measuring the mass m and the volume V separately and then calculating the density

$$\rho = \frac{m}{V} \quad (I)$$

from these quantities.

The density of solids is determined by combining weighing and a volume measurement. The volumes of the bodies are determined from the volume of the liquid that the bodies displace from an overflow reservoir. This procedure is tested in the experiment with regular bodies whose volumes can be calculated from their linear dimensions.

Setup

The experimental setup is illustrated in Fig. 1.

- Put a small quantity (approx. 0.1 cm^3) of colouring into the plastic beaker, pour in water, and stir until the colouring has completely dissolved.
- Supply the glass cylinder (a) with an overflow tube and a rubber stopper, and put it onto the laboratory stand so that the opening of the overflow tube is placed above the centre of the graduated cylinder (b).
- Pour coloured water into the glass cylinder.
- Fill water into the plastic beaker (c) once more, and slowly pour water into the glass cylinder (a) until the overflow tube is filled with bubble-free water and the coloured water overflows into the graduated cylinder.
- Empty the graduated cylinder (b) (pour the coloured water back into the plastic beaker), and put it back under the opening of the overflow tube.

Fig. 1 Experimental setup for determining the volume of solids

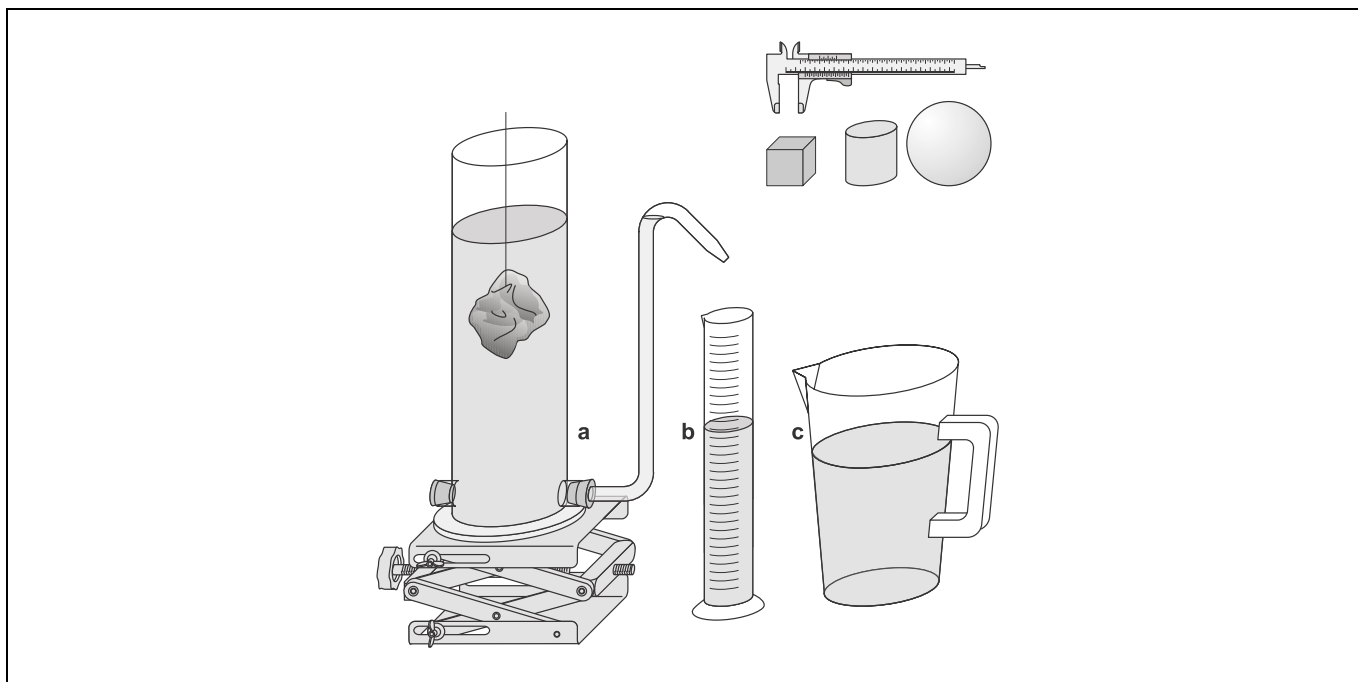

Apparatus

1 set of 2 cubes and 1 ball	361 63
1 set of 2 gauge blocks	590 33
1 glass cylinder with 3 tubes	361 44
1 graduated cylinder	665 755
1 plastic beaker 1000 ml	590 06
1 precision vernier callipers	311 54
1 school and lab. balance	315 05
1 laboratory stand II	300 76
1 cord, 10 m	309 48
1 colouring	309 43

Measuring example:

Table 1: Volume (measured according to the overflow method), dimensions and mass of the test bodies.

body	volume $\frac{V}{\text{cm}^3}$	dimensions		mass $\frac{m}{\text{g}}$
		$\frac{d}{\text{cm}}$	$\frac{h}{\text{cm}}$	
cube 1	27	3.0		20
cube 2	27	3.0		0.29
ball	270	8.0		7.86
cylinder	88	4.5	5.5	239.8
block	32	4.0	2.0	249.6
stone	50			119

Carrying out the experiment

- With a bent piece of wire press the wooden cube completely under the water in the glass cylinder. Determine the quantity of water displaced, and take it down (see Fig. 2).
- Take the wooden cube out of the water, dry it, measure its dimensions with the precision vernier callipers, and record them.
- Determine the mass of the wooden cube, and take it down.
- Repeat the measurements with the styrofoam bodies. Each time pour coloured water from the plastic beaker into the glass cylinder until the overflow tube is filled with bubble-free water, and empty the graduated cylinder.
- For measuring the aluminium cylinder and the steel block, bind cord around the test bodies, and immerse them into the overflow reservoir after filling the reservoir anew (see Fig. 2).
- Finally determine the volume and the mass of an arbitrary stone.

Evaluation and results:

Table 2: Measured and calculated volumes of the test bodies.

body	measured	calculated	formula
cube 1	27	27	$V = a^3$
cube 2	27	27	$V = a^3$
ball	270	268	$V = \frac{4\pi}{3} \cdot \left(\frac{d}{2}\right)^3$
cylinder	88	87.5	$V = \pi \cdot \left(\frac{d}{2}\right)^2 \cdot h$
block	32	32	$V = a^2 \cdot h$

In Table 2, the volumes measured according to the overflow method are compared with those calculated from the dimensions. Within the accuracy of measurement, the values are in agreement. Therefore, one can expect that the overflow method is suitable for determining the volume of the stone with an irregular shape.

In Table 3, the densities ρ of the test bodies calculated from the measured values V and m according to Eq. (I) are compiled.

Table 3: The densities ρ of the test bodies calculated from the measured values V and m according to Eq. (I)

body	$\frac{\rho}{\text{g cm}^{-3}}$
cube 1	0.74
cube 2	0.011
ball	0.029
cylinder	2.74
block	7.8
stone	2.38

Fig. 2 Immersing the test bodies

